



## Features & Options

- 0 to 40 ppm CO Measurement Range
- 30 ppm CO Relay Trip Level with Audible Alarm
- Field Selectable 0 to 5V, 0 to 10V or 4 to 20mA Output
- BAPI-Stat “Quantum” with LED Status Indication
- Automatic Barometric Pressure Compensation

The BAPI-Stat “Quantum” Carbon Monoxide Sensor features a modern enclosure style with green/red status LED. It has a 0 to 40 ppm CO measurement range with a 30 ppm relay/audible alarm trip level. The relay is field selectable for normally closed or normally open, and the CO output level is field selectable for 0 to 5V, 0 to 10V or 4 to 20mA.

The green/red LED indicates unit status of normal, alarm, trouble/service or test. The side pushbutton places the unit into test status to verify audible alarm and LED operation. The sensing element has a typical life of 7 years.



**CO Sensor in a BAPI-Stat “Quantum” Enclosure**

(Bottom unit shown w/ optional 60mm mounting base)

## Specifications

**Power Supply:** 24 VAC/VDC  $\pm 10\%$ , 1.0 VA Max

**CO Sensor Technology:** Electrochemical

**CO Detection Range:** 0 to 40 ppm

**CO Accuracy:**  $\pm 3\%$  of Full Scale

**Jumper Selectable Analog Output:**  
or 4 to 20mA, 0 to 5VDC or 0 to 10VDC

**Relay Trip Point:** 30 ppm

**Relay Output:** Form “C”, 0.1A-30VDC, Normally Closed (NC) and Normally Open (NO) contacts

**Audible Alarm:** 75 dB at 10 feet

**Start-Up Time:** <10 Minutes

**Response Time:** < 5 Min (after Start-Up Time)

**Termination:** 6 Terminals, 16 to 22 AWG

**Environmental Operating Range:**

40 to 100°F (4.4 to 37.8°C)  
0 to 95%RH non-condensing

**Altimeter:** Mechanical

**LED Behavior:**

Red/Green LED indicates the unit status of Normal, Alarm, Trouble/Service or Test.

**Encl. Material & Rating:** ABS Plastic, UL94 V-0

**Mounting:** 2”x4” J-Box or drywall, screws provided

**Sensing Element Life:** 7 years typical

**Certifications:** RoHS

**Warranty Period:** 5 years

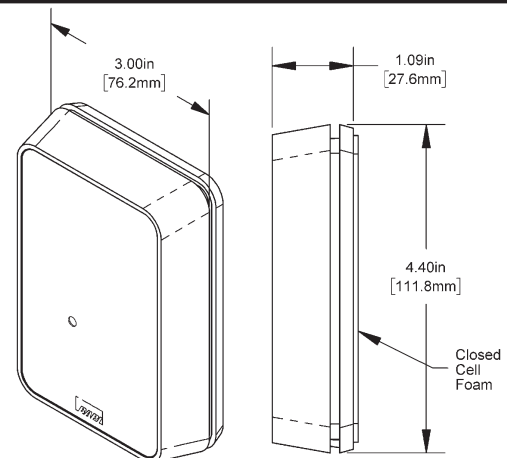

### Unit Dimensions

(bottom unit shown w/ 60mm mounting base for European wall boxes)

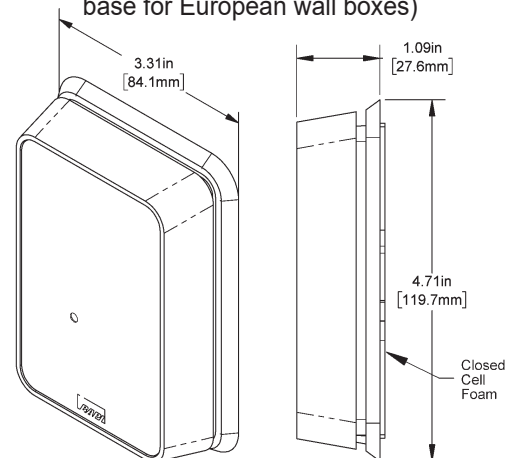



### Ordering Information

<u>Part #</u>	<u>Description</u>
BA/DQX.....	BAPI-Stat “Quantum” Carbon Monoxide (CO), Standard Mounting Base
BA/DQX60.....	BAPI-Stat “Quantum” Carbon Monoxide (CO), 60mm Mounting Base

*Note: Sensors must be installed and powered within 4 months of purchase to prevent loss of accuracy.*

